

Malte Compact



The Malte Compact unit offers a ready-to-use solution with a single tank featuring three chambers for versatile fuel storage.

The Malte Compact accommodates 4.9 to 9.9 liters of fuel, including options like 5.9, 7.2, 9.9, 2x3.6, 2x4.9, and 2.5+2.5+4.9 m³ for various liquid fuels. With a maximum capacity of 9,900 liters, it can be installed in Sweden without on-site installation control. The standard setup includes a dispenser, electric central, and a filling room, with optional integration for payment terminals. We can also provide pre-configured units for dispensers and payment terminals from different suppliers upon request. The fuel tank features a square steel design within an outer steel box for corrosion protection, with standard anodes inside. An optional interior coating is available. The unit is built within a corrosion-resistant steel frame, covered in custom-paintable sinus plates. It includes a customizable ramp and space for signage.

Refilling the fuel tank is simple, with a lockable door at the rear short side. It features dripless couplings, a 150-liter spill tray, and an overfill prevention system. The dispenser area has a non-slip aluminum surface with ceiling-mounted LED lights.

Delivery of the Malte Compact unit is hassle-free, arriving as a package ready for placement. It only requires electrical connection and vent pipe assembly. The installation surface should be a hardened gravel, concrete, or similar even surface. Final on-site assembly can be completed in a single working day with our provided instructions.

Seamless communication

The dispenser is equipped with advanced electronics capable of handling most market protocols, facilitating seamless connections to card terminals or cash systems. It's approved for integration with Bank Card terminals.

Moveable

Compact design

Flexible

Smaller fuel volumes

Custom branding

- Supports various alternative fuels
- Methanol, Alcylate, RME, Diesel, HVO, RME, and more
- Secure, lockable fuel filling space
- Compact footprint

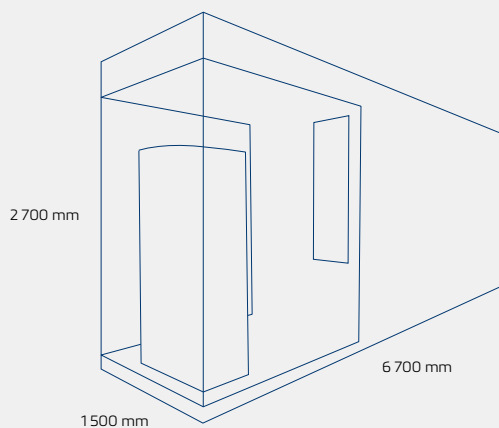

Standard features

- Sinus plates RAL 9006
- Ramp available in all various RAL colors
- Petrotec dispensers
- Single fuel – P1000
- Dual fuels – P2000

Optional features

- Level measurement
- Compatible with common dispensers in the market
- Supports common payment terminals in the market
- Customer Profiling
- Stainless steel tank
- Flame arresters for gasoline
- Dispenser and supply pump equipment for Methanol
- Custom façade colors
- Façade Cassettes
- Storage container option (without dispenser)
- Interior tank coating
- Loading pumps
- And more, tailored to customer requests

Dimensions

- Length: 6 700 mm
- Width: 1 500 mm
- Height: 2 700 mm