

# Malte IBC



**Malte IBC introduces a new solution for alternative fuels that simplifies logistics with unmatched efficiency. Refuelling is as simple as replacing the IBC (Intermediate Bulk Container), and the system can be tailored to meet a variety of needs.**

From alkylate petrol for machinery to AdBlue, washing fluid, and methanol for vehicles, each liquid requires specific equipment, seamlessly integrated into the manufacturing of the unit. The unit is modular, with a consistent base complemented by unique properties for each liquid, ensuring versatility and cost-effectiveness.

#### **Simplifying logistics for alternative fuels**

Secure tank storage with lockable doors on the rear short side. Optional alarm for added security. MID Certified Dispenser as standard for alkylate, diesel, RME, HVO, or methanol, ensuring precise measurement and quality. Additional MID certified

dispenser options for AdBlue or washer fluid can be connected where needed. Dispenser can link to an external payment terminal or cash register. Coated steel walls offer superior corrosion protection. Every component is carefully adapted to the products the unit handles, guaranteeing high quality without compromises. Malte IBC is a smart solution for handling smaller volumes locally, streamlining logistics with optimized efficiency.

#### **Seamless communication**

The dispenser is equipped with advanced electronics capable of handling most market protocols, facilitating seamless connections to card terminals or cash systems. It's approved for integration with Bank Card terminals.

### Flexible

Easy IBC container replacement

Easy installation

Custom branding

- Adaptable for AdBlue, methanol, flushing fluid, alkylate, RME, diesel, or HVO
- No-fuss refilling

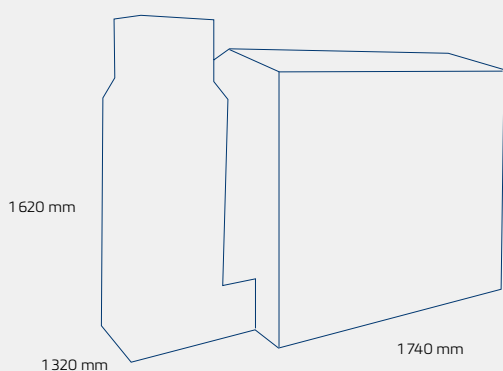

### Standard features

- Petrotec P1000 pump
- Facade color RAL 9016
- Lockable door for tank space
- Front wall fire protection

### Optional features

- Level measurement
- Payment terminal
- Insulated and heated space
- Flame arrester for alkylate
- Pumping equipment for mixed washer fluid
- Pumping equipment for methanol
- Facade color options
- Spill tray (100%)
- Alarm

### Dimensions

	Storage unit	Platform	Door
Length	1740 mm	670 mm	
Width	1320 mm	610 mm	1160 mm
Height	1620 mm	300 mm	1450 mm