

Malte Retail



Introducing Malte Retail, your solution for a high-efficiency and commercially attractive fuel supply unit designed for the retail market.

Whether you need diesel, petrol, ethanol, methanol, HVO, RME, or similar products, Malte Retail has you covered. Our system can handle up to five different products and comes in volumes ranging from 18.4 to 80 m³, with customizable compartments from one to five.

Malte Retail is suitable for various applications, including retail, commercial, industrial, and easily accessible locations. As a buyer, you can select from small, medium, and large platforms to meet your specific needs and location. Malte Retail offers a standard sinus facade in various colors or the option of a cassette facade with an unlimited choice of colors. Our units are constructed to meet local regulations in each country, ensuring safety and adherence to standards. Rein-

forced outer walls act as secondary containment and provide weather protection for the entire unit. All visible surfaces are coated in C4 quality, with C3 quality used elsewhere. Custom coating options are available upon request.

The unit is equipped with technical room with an internal electrical central and space for level measurement, alarms, modems, and more. Malte Retail can be fitted with dispensers and payment terminals from common manufacturers in the market. The unit meets the requirements for a 12-year inspection interval according to Scandinavian regulations. Malte Retail is delivered with all safety requirements, a fully enclosed tank, a lockable 150-liter spill tray under the filling location, and an electrical anti-siphon function.

Movable

Above ground

Reliable

Adaptable

Custom branding

- Cost-effective
- Smaller footprint compared to round tanks
- At 15.1 meters in length, no following car is needed for transport in Europe
- Easy to relocate
- Attractive Design

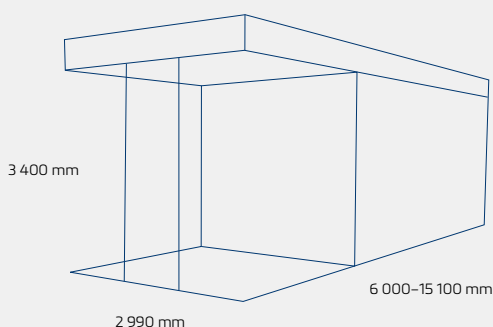

Standard features

- Standard chassis color in RAL 7024 with a range of RAL color options for the sinus 18 facade
- Designed to accommodate dispensers from any manufacturer
- Operating temperature from -40°C to $+40^{\circ}\text{C}$ as standard for both tank and pipes
- Includes a 150-liter spill tray in the loading area
- Plug & Play
- Easy installation
- Flexible
- Eco-Friendly
- Roof hatches for convenient access to tank and level equipment
- Fire-protected walls in the loading room and front wall to dispensers
- Electrical room with indoor climate control and full electrical safety
- Secondary compartment for tank, spill tray under the dispenser platform
- Electrical anti siphon function

Optional features

- Loading pump (up to 3)
- Custom colors
- Weather shelter
- Level measurement
- Graphic profile customization
- Extra overfill protection
- Integration of AdBlue tanks (4 or 8 m^3)
- Integration of Windscreen liquid tanks (3 or 4 m^3)
- LED stripe for enhanced visibility
- QR payment system
- Payment terminal
- Fully coated tank
- Malte Level Control System
- Automatic water drainage
- Additional options available upon request

Dimensions

- Width: 2 990 mm
- Height: 3 400 mm
- Min Length: 6 000 mm
- Max Length: 15 100 mm
- Min Volume: 18.4 m^3
- Max Volume: 80 m^3